

LARGE STEALTH FRAMING PROJECTOR

MO-1224 MONOPOINT LUMINAIRE

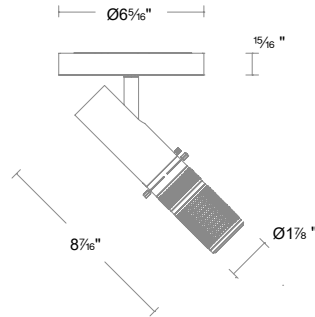

Fixture Type:

Catalog Number:

Project: _____

Location: _____

PRODUCT DESCRIPTION

The sleek, stylish luminaire projects a square, rectangular or circular area of light with crisp lines to frame or highlight art objects, providing maximum visual impact. Like a quality camera lens, the innovative projector contains adjustable lenses as well as shims to frame a sharp accenting light the width and length of the object. It can zoom-in for a closeup or zoom out to frame larger pieces of art.

FEATURES

- Precise, high definition zoomable projection
- Stealth armature with 360° horizontal rotation and 90° vertical aiming
- Accepts one glass or metal Gobo. Custom size
Outside Diameter: 24.5mm, Thickness: ≤ 1.5mm, Image Size: ≤ 19mm.
- Ceiling and wall mountable
- 5 year warranty

SPECIFICATIONS

Construction:	Die-cast aluminum with optical glass lenses
Power:	24W
Input:	120-277V AC 50/60Hz
Dimming:	100%-5% ELV, TRIAC (120V only), 0-10V
Light Source:	Integrated LED, 3 Step Mac Adam Ellipse
Rated Life:	50000 Hours
Finish:	Electrostatically Powder Coated and Anodized: Black, White
Operating Temp:	-4°F to 104°F (-20°C to 40°C)
Standards:	ETL & cETL Damp Location listed

ORDERING NUMBER

System	Model	Power	CRI	Color Temp	Beam	Lumens	CBCP	Finish			
MO	1224	24W	90	927	2700K	13°	330	8400			
					930	3000K	35°	565	2010		
						935	3500K	13°	355	8935	
					940		4000K	13°	605	2140	BK
						35°		370	9385		
					35°	635	2245	WT	White		
					13°	380	9650				
					35°	650	2310				

MO-1224-

Example: MO-1224-930-WT

EXTENSIONS *Custom order as a complete unit. Ceiling mount only.*

Model	Color Temp	Finish
X6 6"	927	BK
X12 12"		
X18 18"		
X24 24"		
X36 36"		
X48 48"		
MO1224	930	WT
	935	
	940	

Example: X48-MO1224940BK

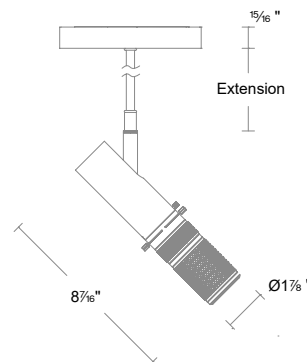

wacighting.com

Phone (800) 526.2588

Fax (800) 526.2585

Headquarters, East Manufacturing Facility

44 Harbor Park Drive

Port Washington, NY 11050

South East Manufacturing Facility

1600 Distribution Ct

Lithia Springs, GA 30122

Central Manufacturing Facility

1700 South J Elmer Freeway, Ste 100

Cedar Hill, TX 75104

West Manufacturing Facility

1750 S Archibald Ave

Ontario, CA 91761

LARGE STEALTH FRAMING PROJECTOR

MO-1224 MONOPOINT LUMINAIRE



APPLICATION PERFORMANCE

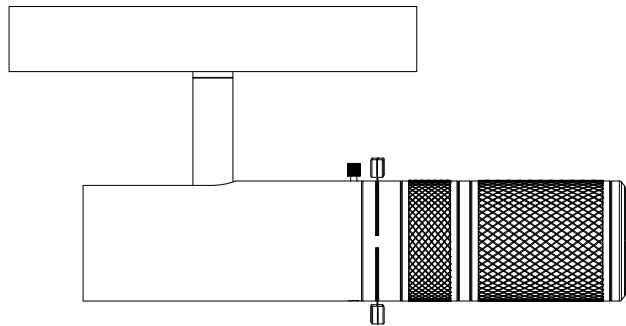

Zoomable MO-1224 @ 3000K

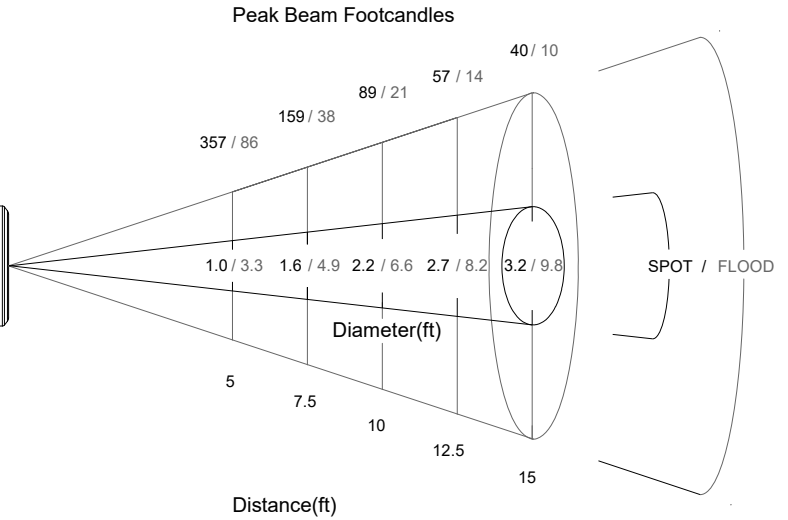

Distance (ft)	5	7.5	10	12.5	15
Maximum square projection using framing shims (ft)	2	3	4	5	6

Above guidelines represent straight on aiming angle. Results may vary. Mockup in site conditions recommended.

wacighting.com

Phone (800) 526.2588

Fax (800) 526.2585

Headquarters, East Manufacturing Facility

44 Harbor Park Drive

Port Washington, NY 11050

South East Manufacturing Facility

1600 Distribution Ct

Lithia Springs, GA 30122

Central Manufacturing Facility

1700 South J Elmer Freeway, Ste 100

Cedar Hill, TX 75104

West Manufacturing Facility

1750 S Archibald Ave

Ontario, CA 91761